

User Instruction

Ax1

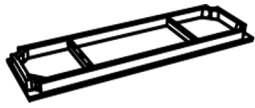

Bx1

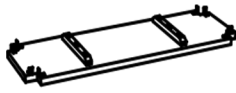

Cx4

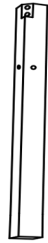

Dx8

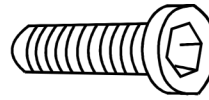

M8 x 40 mm

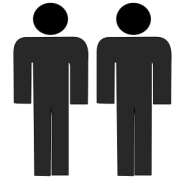

Require 2 Persons for assembly

Ex16



Fx8

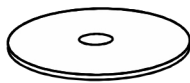

Gx1



Hx1



STEP-1

UNPACK ALL PARTS
(TOP A,BOTTOM SHELF B AND LEG C) CAREFULLY.

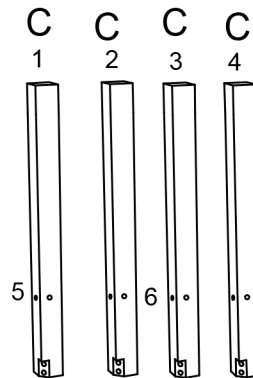
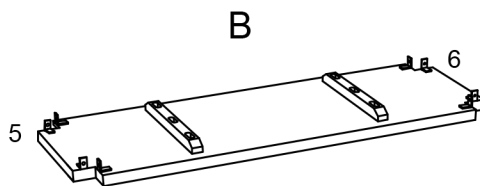
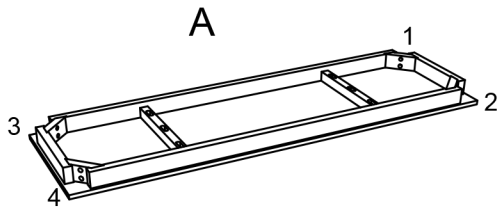

STEP-2

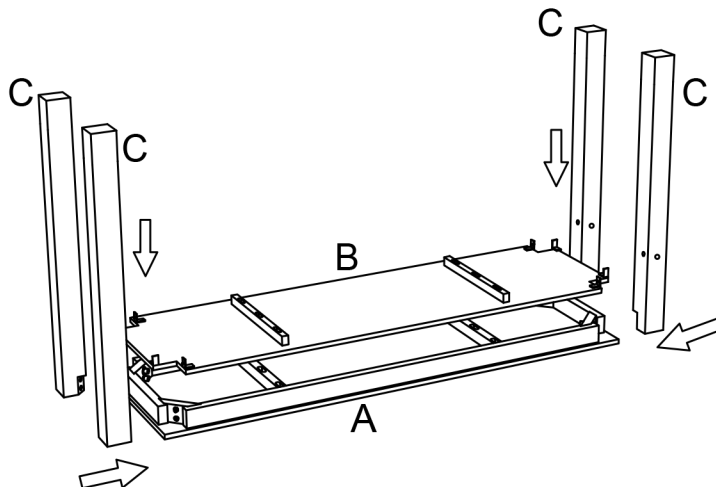

STEP-3

ASSEMBLE PART (B) & (C) BY MATCHING NUMBER (5-5,6-6) USING THE HARDWARE (E) WITH THE HELP OF ALLEN KEY H

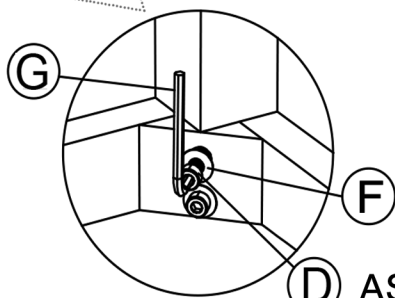
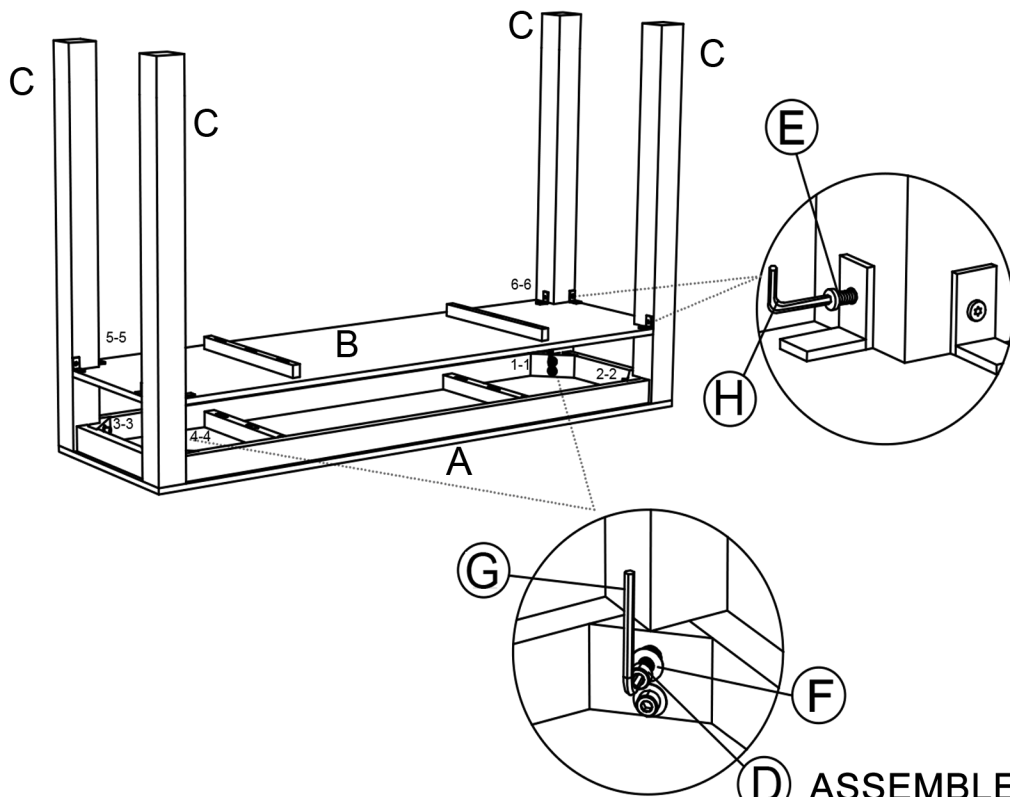

ASSEMBLE PART (A) & (C) BY MATCHING NUMBER (1-1,2-2,3-3,4-4) USING THE HARDWARE (D) AND (F) WITH THE HELP OF ALLEN KEY G

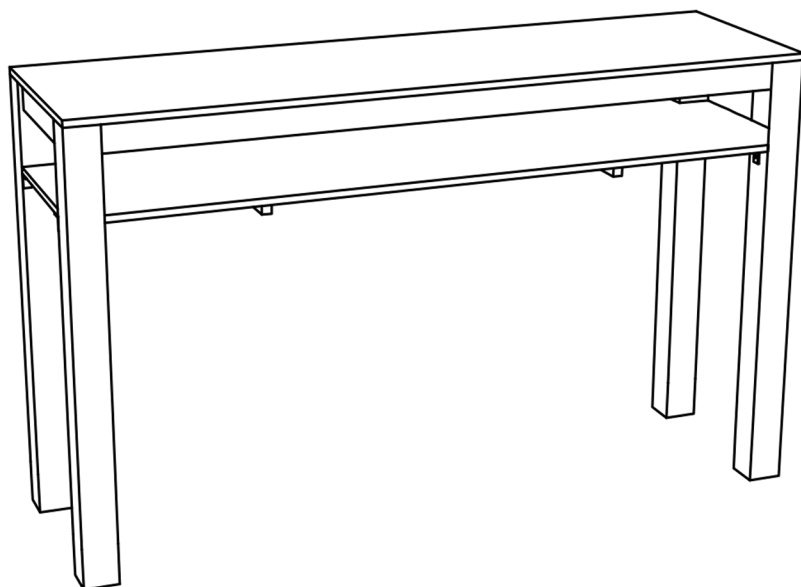

Assembled Piece